

# Corian® Specification Sheet : 4212 Washplane

[Revised November 2019]

## Notes:

- Tap hole cutouts not included, drawing for location reference only.
- All external edges sanded to 2mm radius
- Top surface sanded to semi-gloss finish

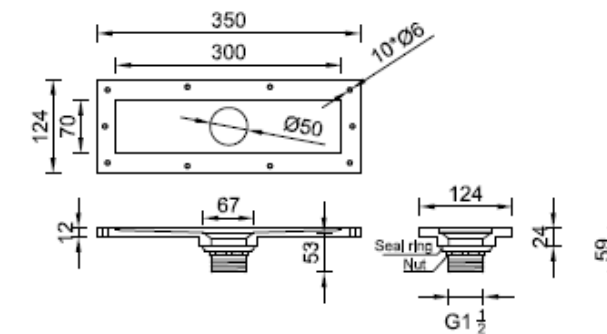
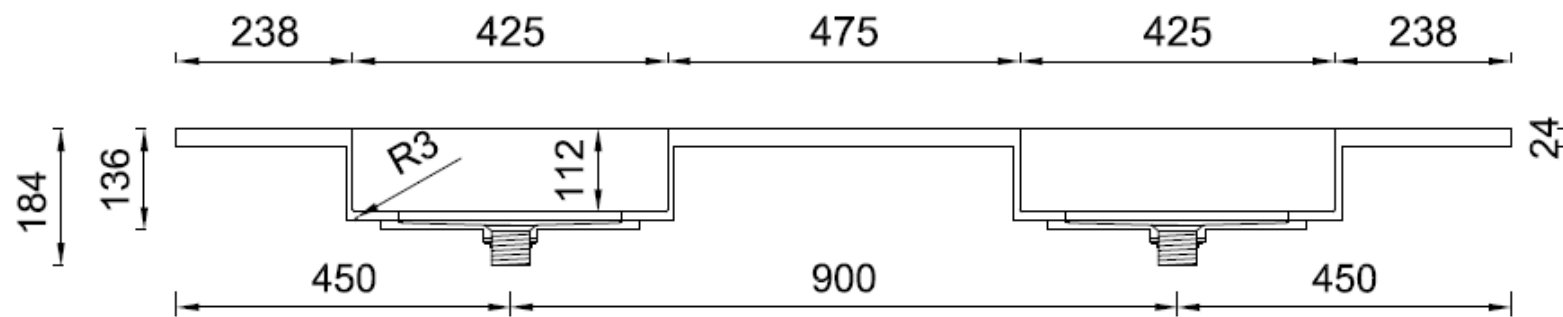
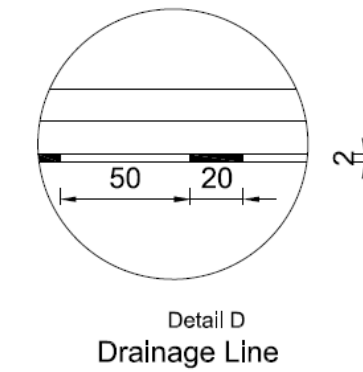
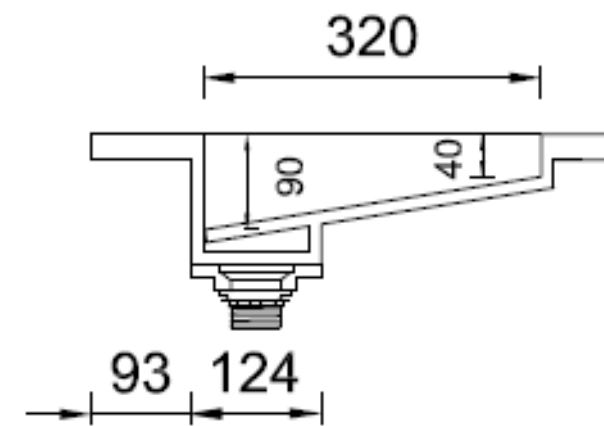
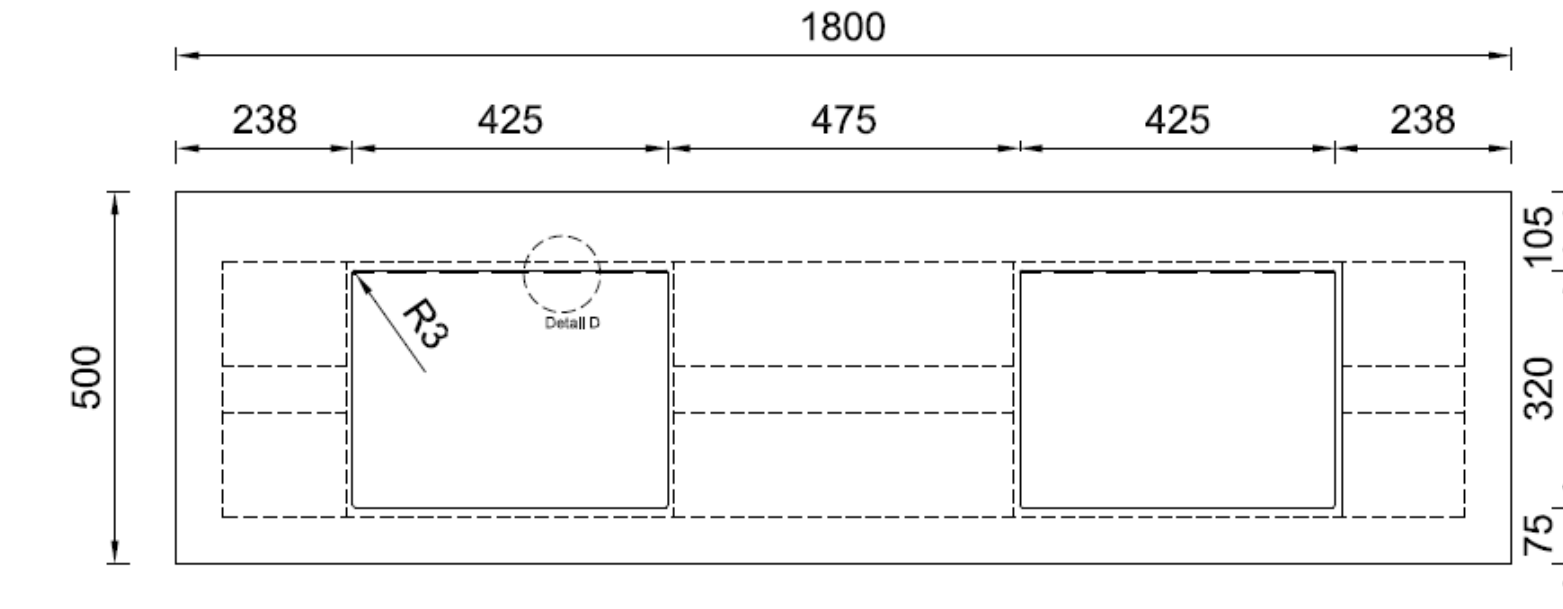

Waste Kit



Head Office & Showroom

2/5-11 Mellor St, West Ryde NSW 2114  
P: 1300 795 485 E: info@scfinteriors.com.au



3	2 waste fittings, pre-assembled to #2
2	2 waste kits, pre-assembled to #1
1	1 Corian Washplane 4212
#	Packing List