

# Corian® Specification Sheet : 3212 Washplane

[Revised November 2019]

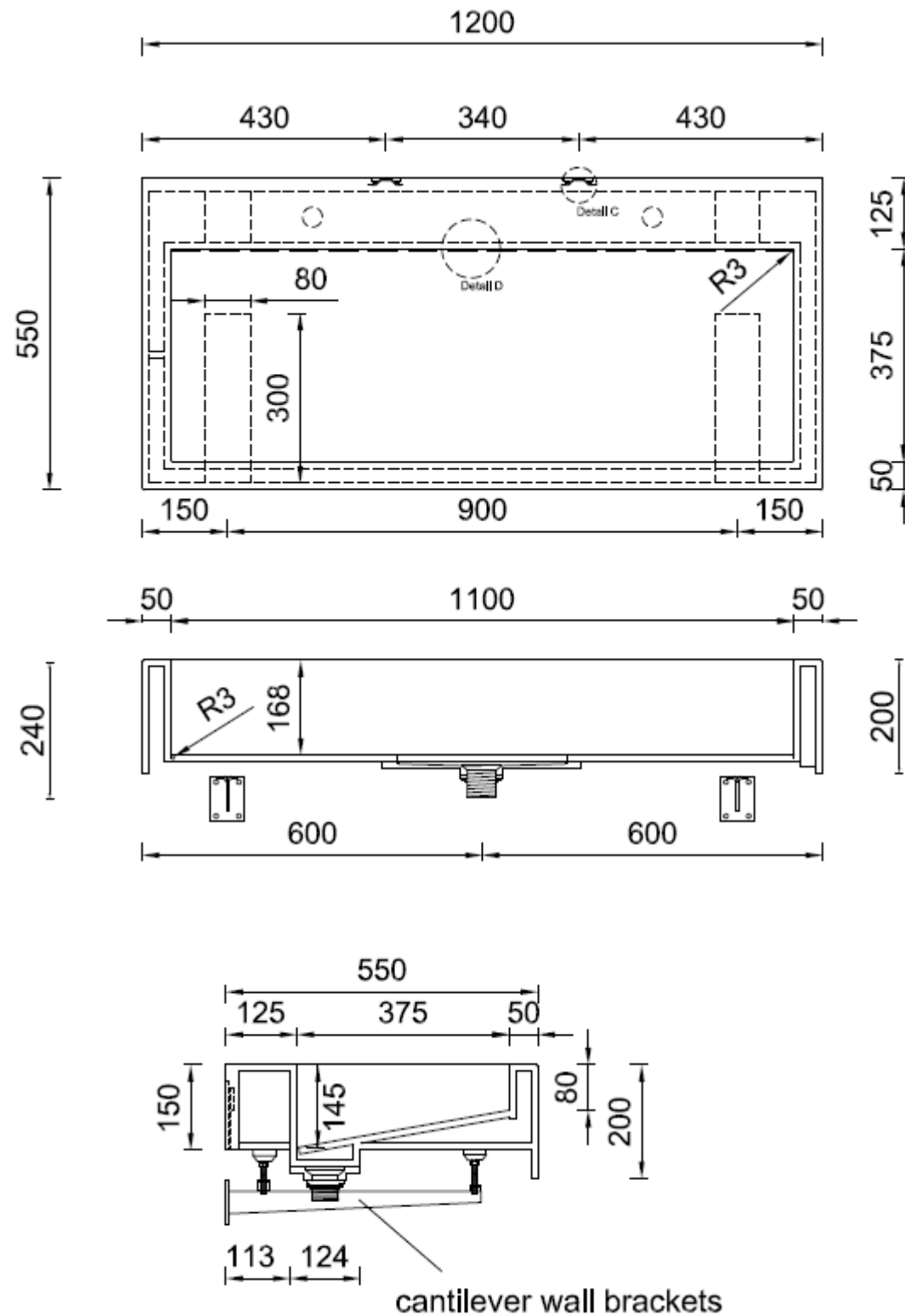

## Notes:

Tap hole cutouts not included, drawing for location reference only.  
 All external edges sanded to 2mm radius  
 Top surface sanded to semi-gloss finish

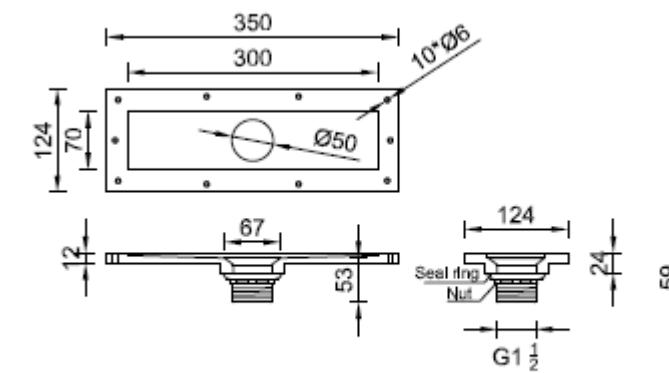
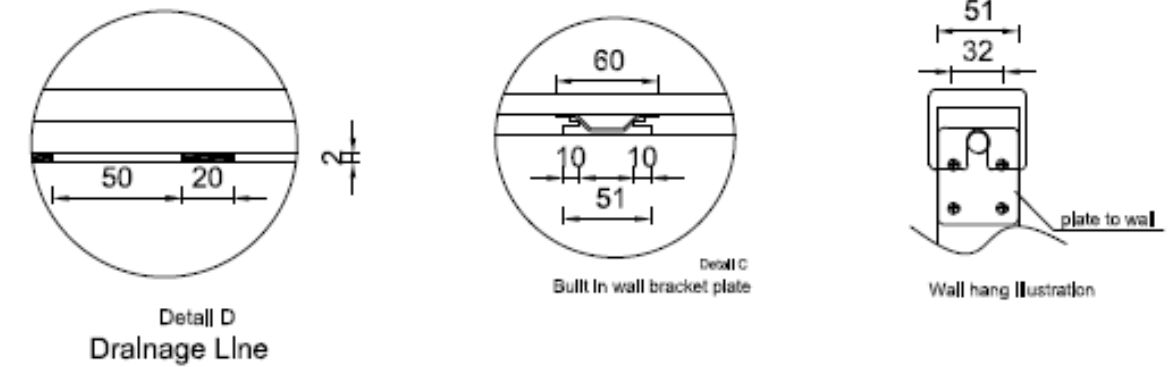

Waste Kit

6	1 plywood wall bracket template
5	2 wall bracket fixing plates & screws
4	2 x 450mm adjustable cantilever wall brackets & screws
3	1 waste fitting, pre-assembled to #2
2	1 Corian waste kit, pre-assembled to #1
1	1 Corian Washplane 3212
#	Packing List



Head Office & Showroom  
 2/5-11 Mellor St, West Ryde NSW 2114  
 P: 1300 795 485 E: info@scfinteriors.com.au

